

John Deere JD540-B Skidder and Grapple Skidder Operation and Tests



TECHNICAL MANUAL

TM-1139 (Oct-87)

LITHO IN U.S.A.

JD540-B SKIDDER - GRAPPLE SKIDDER

Technical Manual
TM-1139 (Oct-87)

SECTION AND GROUP CONTENTS

SECTION I - GENERAL INFORMATION

- Group I - Contents, Index and Page List
- Group II - Introduction and Safety Information
- Group III - General Specifications
- Group IV - Predelivery, Delivery and After-Sale Services (not included)
- Group V - Lubrication

SECTION 90 - SYSTEM TESTING

- Group 9005 - General Information
- Group 9010 - Engine
- Group 9015 - Electrical System
- Group 9020 - Power Train
- Group 9025 - Hydraulic System (Flow Meter)
- Group 9025A - Hydraulic System (Analyzer)
- Group 9030 - Miscellaneous Components
- Group 9031 - Heating and Air Conditioning
- Group 9035 - Specifications and Special Tools

The specifications and design information contained in this manual were correct at the time it was printed. It is John Deere's policy to continually improve and update our machines. Therefore, the specifications and design information are subject to change without notice.

Copyright© 1987
DEERE & COMPANY
Moline, Illinois
All Rights Reserved

Previous Editions
Copyright© 1983 Deere & Company
Copyright© 1980 Deere & Company
Copyright© 1979 Deere & Company
Copyright© 1977 Deere & Company
Copyright© 1976 Deere & Company

**Thanks very much for your reading,
Want to get more information,
Please click here, Then get the complete
manual**

JustClickHere 

NOTE:

**If there is no response to click on the link above,
please download the PDF document first, and then
click on it.**

**Have any questions please write to me:
admin@servicemanualperfect.com**

Group II INTRODUCTION AND SAFETY INFORMATION

INTRODUCTION

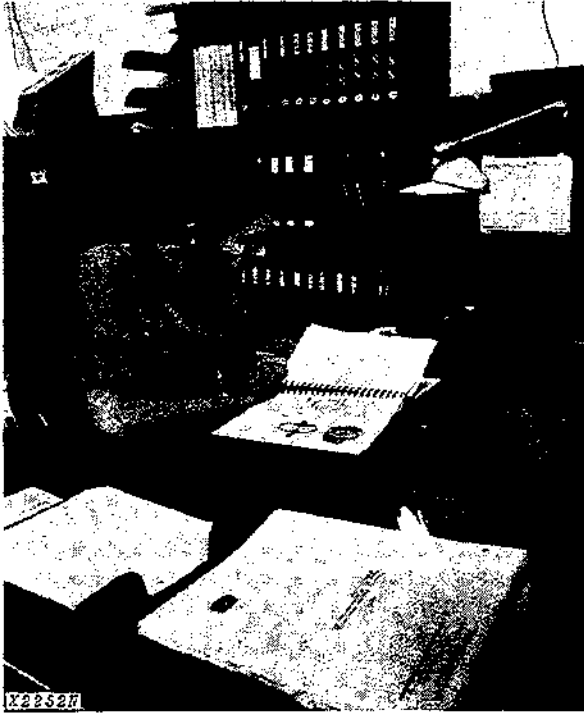

Use FOS Manual for Reference

This technical manual is part of a twin concept of service:

The two kinds of manuals work as a team to give you both the general background and technical details of shop service.

•FOS Manual—for reference

Fundamentals of Service (FOS) Manuals cover basic theory of operation, *fundamentals* of trouble shooting, *general* maintenance, and *basic* types of failures and their causes. FOS Manuals are for training new personnel and for reference by experienced service technicians.



When a service technician should refer to a FOS Manual for more information, a FOS symbol like the one at the left is used in the TM to identify the reference.

•Technical Manuals—for actual service

Technical Manuals are concise service guides for a specific machine. Technical manuals are on-the-job guides containing only the vital information needed by an experienced service technician.

Litho in U.S.A.



Use Technical Manuals for Actual Service

This technical manual was planned and written for you—an experienced service technician. Keep it in a permanent binder in the shop where it is handy. Refer to it whenever in doubt about correct service procedures or specifications.

Some features of this manual:

- Inside front cover - "Table of Contents".
- Section I - Contents, safety information, general specifications and general services.
- Sections 1 through 40 - Removal, repair, testing (components removed), installation, and adjustment.
- Section 90 - Detailed explanation of system operation, diagnosis, visual inspection, testing, and adjustments.
- Specifications grouped and illustrated at the end of each section.

MAINTENANCE WITHOUT ACCIDENT WORK SAFELY



T27999N

 This safety alert symbol is used for important safety messages. When you see this symbol, the possibility of personal injury exists if safety message is not followed.

EVERY EMPLOYER HAS A SAFETY PROGRAM. KNOW WHAT IT IS!

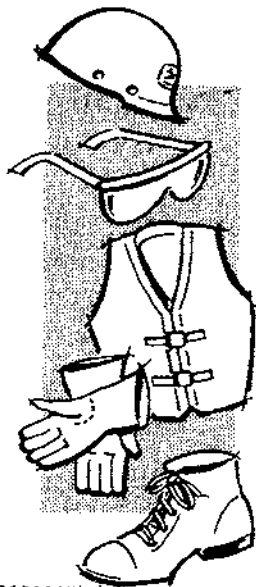

T27501N

Consult your shop supervisor for specific instructions on a job, and the safety equipment required.

For instance, you may need: Hard hat, safety shoes, safety goggles, heavy gloves, reflector vests, ear protectors, respirators.

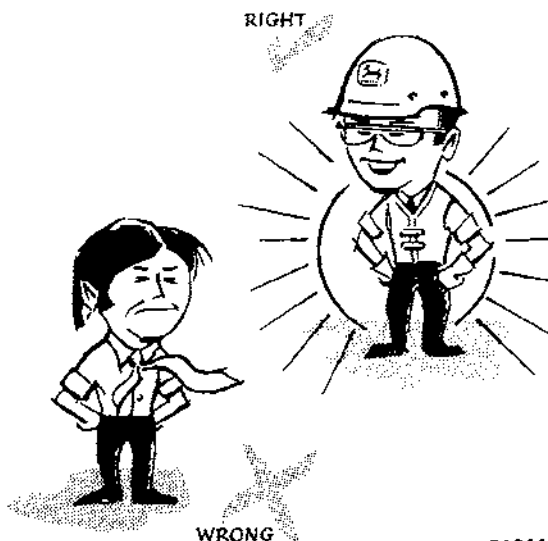

WRONG

T27502N

ALWAYS AVOID loose clothing or any accessory—flopping cuffs, dangling neckties and scarves, or rings and wrist watches—that can catch in moving parts and put you out of work.

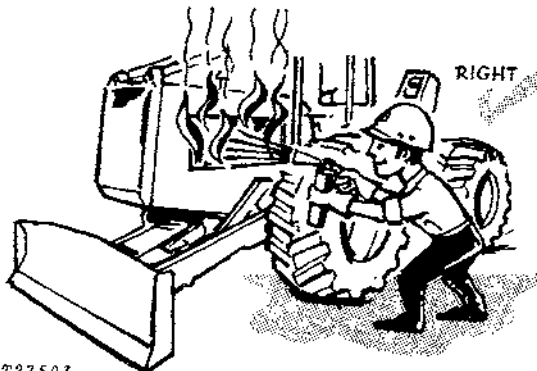

T27503

BE ALERT!

Plan ahead—work safely—avoid accidental damage and injury. If a careless moment does cause an accident or fire, react quickly with the tools and skills at hand—know how to use a first aid kit and a fire extinguisher—and where to get aid and assistance. In an emergency, split-second action is the key to safety.



T27504N

MAINTENANCE WITHOUT ACCIDENT

Specific safety procedures should always be observed, whether servicing or making repairs on the skidder. Remember these—in time!—can prevent an injury . . . or save your life. . . .

AVOID FIRE HAZARDS—

Fuel Is Dangerous!

- Don't smoke while refueling.
- Don't smoke while handling highly flammable material.
- Engine should be shut off when refueling.
- Use care in refueling if the engine is hot.

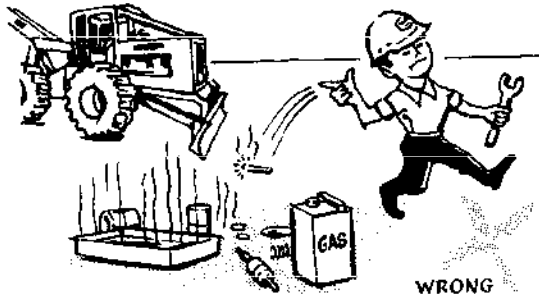

T33257N

Don't use open pans of gasoline or diesel fuel for cleaning parts. Good commercial, nonflammable solvents are preferred.

Battery Gas Is Highly Flammable!

Provide adequate ventilation when charging batteries.



T27508N

Don't check battery charge by placing metal objects across the posts.

- Don't allow sparks or open flame near batteries.
- Don't smoke near battery.

Flame Is Not a Flashlight!

Never check fuel, battery electrolyte or coolant levels with an open flame.

Never use an open flame to look for leaks anywhere on the equipment.

Never use an open flame as a light anywhere on or around the equipment.

KNOW WHERE FIRE EXTINGUISHERS ARE KEPT!

UNDER ALL MAINTENANCE CONDITIONS—

Do not perform any work on the skidder unless authorized to do so. Then be sure you understand the services required. Follow recommended procedures.

Never service the equipment while it is being operated.

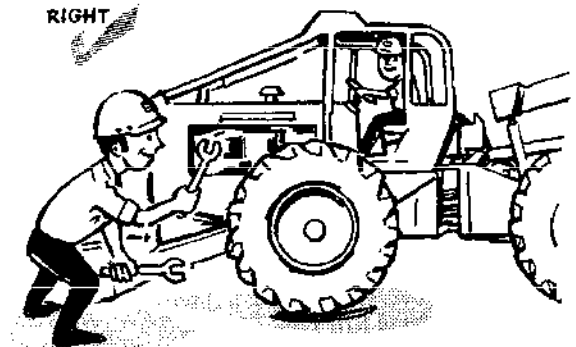

T33258N

Avoid working on equipment with the engine running. If it is necessary to make checks with the engine running, **ALWAYS USE TWO SERVICE TECHNICIANS**—one, the operator, at the controls, the other checking in view of the operator. Also, put the transmission in neutral, set the brake, and apply any safety locks provided. **KEEP HANDS AWAY FROM MOVING PARTS.**

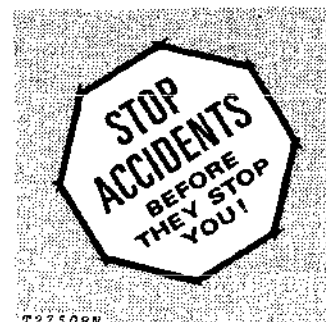

T27509N

MAINTENANCE WITHOUT ACCIDENT

Before servicing, adjusting, or repairing skidders which have attachments such as blades, grapple tongs, etc.—**LOWER** attachments to the ground—or, if necessary to raise them for access to certain parts, **SECURELY SUPPORT** by external means. **DO NOT** rely on controls to support or position attachments for maintenance.

Never allow **ANYONE** to walk under equipment that is raised and not properly blocked.

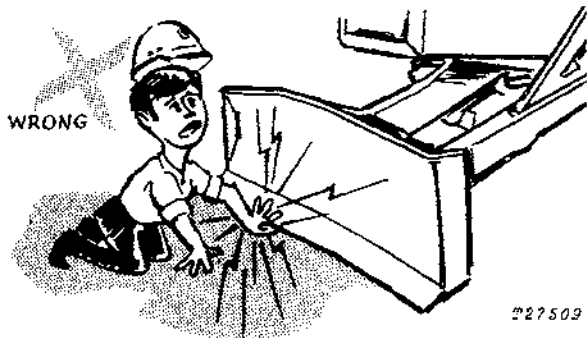

Avoid working directly under raised and blocked equipment unless absolutely necessary.

If the skidder is on an incline, block it securely.

Use hoisting equipment for lifting heavy parts. **TAKE CARE! WATCH OUT FOR OTHER PEOPLE IN THE VICINITY.**

Use extreme caution in removing radiator caps, drain plugs, grease fittings, or hydraulic pressure caps.

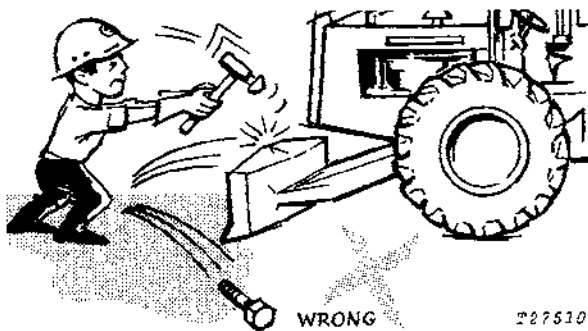

Wear safety glasses when drilling, grinding, or hammering metal.

Make sure the maintenance area is adequately vented.

Keep maintenance area **CLEAN AND DRY**. Oily and wet floors are slippery; greasy rags are a fire hazard; wet spots are dangerous when working with electrical equipment.

Store starting aids in a cool and well-ventilated place, out of the reach of unauthorized personnel.

SERVICING PRECAUTIONS

Stop the engine before cleaning or lubricating the skidder.

Lower blade and grapple to the ground *carefully*.

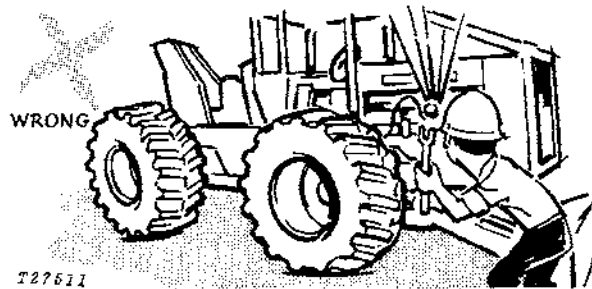

Engine coolant gets hot! Don't remove the radiator cap until coolant temperature is below the boiling point. Then turn cap slightly to relieve pressure before removing.

Exhaust gases are dangerous! Periodically check exhaust system for excessive leakage.

Don't forget a hydraulic system may be pressurized! To relieve system pressure, stop engine, lower blade and boom and operate blade, boom or grapple controls until system fails to respond.

When checking hydraulic pressure, be sure to use the correct test gauge for the pressure in the particular system.

The skidder is equipped with a brake accumulator—recharge by using only dry nitrogen. To discharge brake accumulator apply the brake pedal about 30 times.

MAINTENANCE WITHOUT ACCIDENT

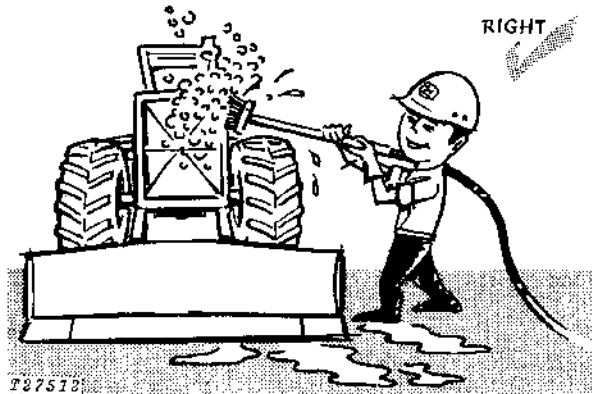

Keep ALL components free of dirt and oil. This attention will minimize fire hazards and facilitate spotting of loose or defective parts.

When preparing engine for storage, remember that inhibitor is volatile and therefore dangerous. Seal and tape openings after adding inhibitor. Keep container tightly closed when not in use.

ADJUSTING PRECAUTIONS

... for Operating Adjustments

Keep clutch and brake control units properly adjusted at all times. Before making adjustments, stop engine.

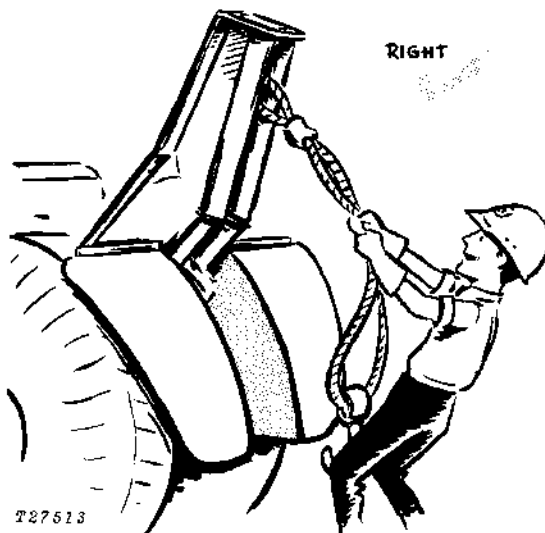

Always wear gloves when handling cable.

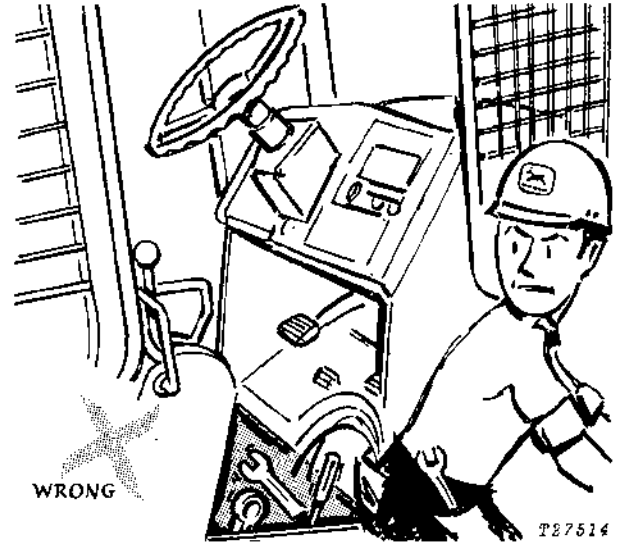

Before removing any housing covers, stop engine. Take all objects from your pockets which could fall into the opened housings. Don't let adjusting wrenches fall into opened housings.

... for Maintenance Adjustments

Don't attempt to check belt tension while the engine is running.

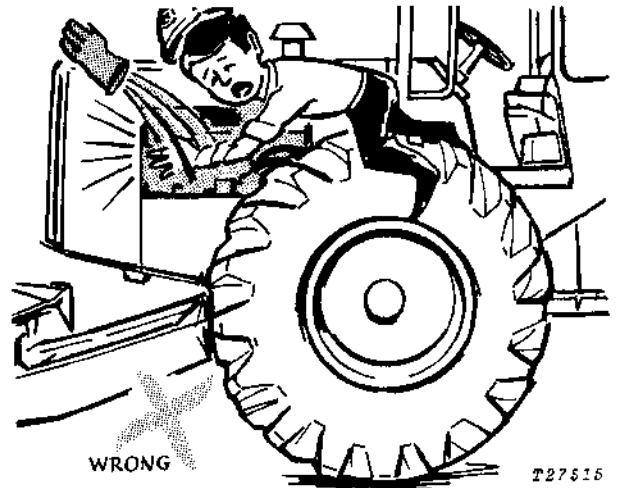

Don't adjust the fuel system while the machine is in motion.

MAINTENANCE WITHOUT ACCIDENT

PRECAUTIONS DURING REPAIR



Before repairing the electrical system, or performing a major overhaul, make sure the batteries are disconnected.

When changing cutting edges on blade—

Stop the engine and securely block the blade.

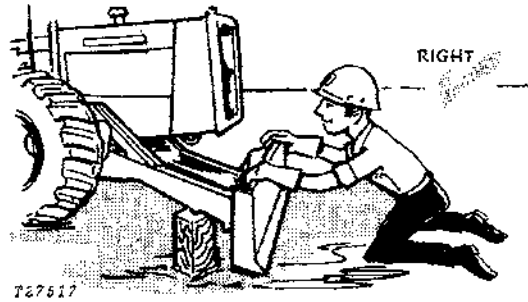

Never let your bare hands come in contact with sharp edges. WEAR GLOVES.

MAINTENANCE WITHOUT ACCIDENT

KNOW EQUIPMENT IS READY!

Check guards, canopies, safety bars—all protective devices installed on the skidder. Every one should be in place and secure.

CHECK IT OUT!

- GUARDS
- CANOPIES
- SHIELDS
- PROTECTIVE DEVICES
- ROLL-OVER PROTECTIVE STRUCTURES
- SEAT BELTS
- FIRE EXTINGUISHER
- FIRE SUPPRESSION SYSTEM, ETC.

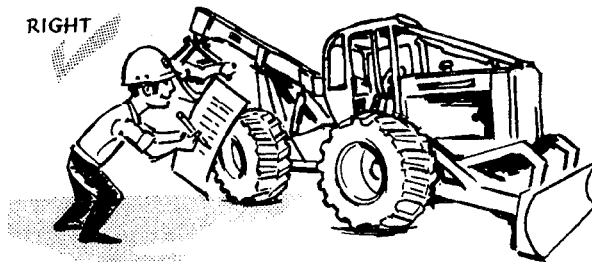

T33262N

Carefully inspect equipment for visual defects—leaks in fuel, lubrication, and hydraulic systems. Do not search for pressurized fluid leaks with your hands. Use cardboard or wood to search for leaks.

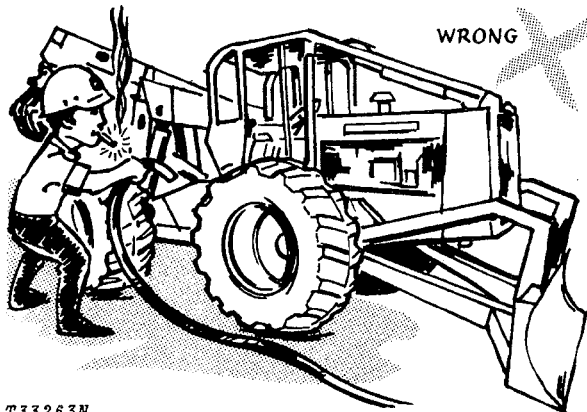

T33263N

Check levels of fuel, coolant, hydraulic fluid, and lubricating oil. If fuel must be added—**FIRST, PUT OUT THAT CIGARET.**

Check and secure all caps and filler plugs for fuel, oils, radiator, etc.

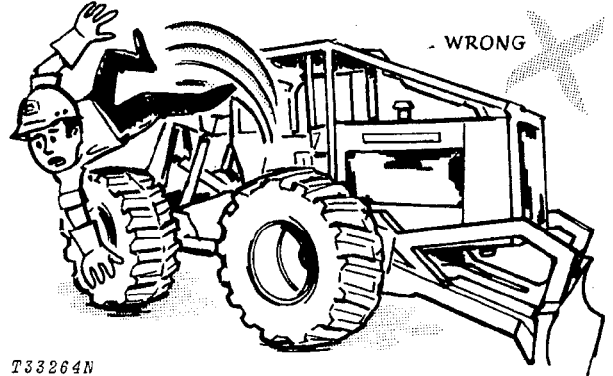

T33264N

Be sure to clean any oil, grease or mud accumulation from floor of operator's compartment, stepping points, and grab rails to minimize the danger of slipping.

In freezing weather beware of snow or ice deposits on stepping points, grab rails, and floor.

Remove loose bolts, tools, or other objects from floor of operator's compartment.

Although it is impractical to try to cover every possible maintenance situation, the safety precautions recommended here should serve to develop and promote safe maintenance procedures.

The information contained in this manual is not intended to replace safety codes, insurance requirements, federal, state, and local laws, rules and regulations. In particular, your service area or jobsite activities may be subject to state safety rules and/or federal regulation under the Occupational Safety and Health Act (OSHA). Familiarize yourself with all regulations applicable to your situation in order to avoid possible safety violations.

Illustrations and copy reproduced in part by permission of Construction Industry Manufacturers' Association (CIMA).



Group III GENERAL SPECIFICATIONS

SKIDDER

(Specifications and design are subject to change without notice. Whenever applicable, specifications are in accordance with ICED and SAE Standards. Except where otherwise noted, these specifications are based on a unit equipped with 23.1-26, 10-ply-rating logging tires and standard equipment).

Power (@ 2200 engine rpm):	SAE	DIN
Gross	96 hp (71.5 kW*)	
Net	90 hp (67.1 kW)	91 PS

Net engine flywheel power is for an engine equipped with fan, air cleaner, water pump, lubricating oil pump, alternator and muffler. The gross engine power is without fan. Flywheel power ratings are under SAE standard conditions of 500-ft. altitude and 85° F. temperature, and DIN 70 020 conditions (non-corrected). No derating is required up to 10,000 feet (3000 m) altitude.

*In the international system of units (SI) power is expressed in kilowatts (kW).

Engine:

John Deere turbocharged diesel, 4-cylinder, 4-stroke cycle
Bore and stroke 4.19x5 in. (106x127 mm)
Piston displacement 276 cu. in. (4 523 cm³)
Compression ratio 16.7 to 1
Maximum torque @ 1400 rpm ... 270 lb-ft (366 Nm)
(37.32 kg-m)
NACC or AMA (U.S. Tax) horsepower 28
Lubrication Pressure system with full-flow filter
Cooling Pressurized with thermostat
and fixed bypass
Fan Blower
Air cleaner with restriction indicator Dry
Electrical system 12-volt with alternator
Batteries (2) Reserve capacity:
170 minutes

Differentials:

Front and rear Full differentials
with hydraulic lock

Engine Clutch Disconnect:

Hand-operated, spring-loaded, dry-disk. Single plate,
12 in. (305 mm).

Transmission:

Power Shift with planetary gears, hydraulically actuated wet-disk clutches and brakes; provides 8 speeds forward—4 reverse. Controlled by single lever on console.

Travel Speeds (2200 engine rpm, no tire slip):

Forward: 1.7 mph (2.7 km/h) to 17.9 mph (28.8 km/h)
Reverse: 2.0 mph (3.2 km/h) to 5.8 mph (9.3 km/h)

Drive Axles:

Four-wheel drive with inboard planetary gears on all axles.
Front axle oscillates 15 degrees above and below horizontal. 20 in. (508 mm) total travel at tire center line.

Brakes:

Hydraulic power actuated, dual controlled disks on 4 wheels, lockable for winching. Hand-operated mechanical brake for parking and emergency stop.

Power Steering:

Articulated frame hydraulically actuated by dual cylinders.
Turning radius 16 ft. 4 in. (4.97 m)
Turning clearance 34 ft. 5 in. (10.49 m)

Hydraulic System:

Closed-center constant pressure. Variable-displacement pump driven from crankshaft... 25 gpm (95 L/min) 2000 psi (137.9 bar) (140.6 kg/cm²) @ 2200 engine rpm. Full flow filtration. Oil cooler integral with radiator.

Tires:

- 18.4-34, 16-ply-rating, kevlar-ply, LS-2*
- 23.1-26, 16-ply-rating, kevlar-ply, LS-2*
- 18.4-26, 10-ply-rating, logging, LS2
- 18.4-34, 10-ply-rating, steel-ply, LS2
- 23.1-26, 10-ply-rating, steel-ply, LS2
- 28.1-26, 10-ply-rating, steel-ply, LS3
- 28.1-26, 14-ply-rating, steel-ply, LS2

*Canada only

Capacities:

	U.S.	Liters
Fuel tank	42 gal.	159.0
Cooling system	8 gal.	30.3
Engine lubrication, including filter	15 qt.	14.2
Transmission and hydraulic system	9 gal.	34.1
Front differential	4.5 gal.	17.0
Rear differential	4.5 gal.	17.0
Winch	2.5 gal.	9.5

SAE Operating Weight 16,675 lb. (7 564 kg)

Winch:

Cable capacities*:

- 1/2-in. (12.7 mm) cable 217 ft. (66.1 m)
- 5/8-in. (15.8 mm) cable 142 ft. (43.3 m)
- 3/4-in. (19.1 mm) cable 100 ft. (30.5 m)

*Calculated: No allowance made for loose or uneven spooling.

Line pull (maximum engine torque):

- Bare drum 30,541 lb. (136.89 kN) (13 853 kg)
- Full drum 18,794 lb. (84.24 kN) (8 525 kg)

Line speed (2200 rpm):

- Bare drum 115 fpm (35.1 m/min)
- Full drum 187 fpm (56.9 m/min)

Blade: Hydraulic control

- Width 6 ft. 11 in. (2.11 m)
- Height (ends) 1 ft. 8 in. (508 mm)
- Height (center) 2 ft. 3 in. (686 mm)
- Max. lift above ground level 4 ft. 4 in. (1.31 m)
- Max. drop below ground level 9 in. (229 mm)

Arch:

- Horizontal roller 6 in. (152 mm) dia.
- Vertical rollers (through-hardened steel)
 4.5 in. (114 mm) dia.
- Working height (top of horizontal roller to ground):
 Settings: Lower—6 ft. (1.83 m)
 Upper—6 ft. 5 in. (1.95 m)

Additional Standard Equipment:

- Muffler
- Fuel gauge
- Engine oil pressure gauge
- Alternator charge warning light
- Water temperature gauge
- Transmission oil temperature gauge
- Transmission oil pressure warning light
- Parking brake warning light and buzzer
- Transistorized voltage regulator
- Electric hour meter
- Key switch with push button safety start
- Horn
- Fire extinguisher
- Flanged axles
- John Deere winch
- Cold weather starting aid
- Heavy duty starter
- Log arch with adjustable rollers
- Engine side shields
- Deluxe seat with suspension
- Cigar lighter
- Foot throttle
- Hand throttle
- Lights
- Front blade
- Integral log bumper
- Roll-over protective structure (ROPS) with canopy,
 seat belt, brush screens, and limb risers
- Vandal protection
- Reinforced bottom guards

Special Equipment:

- Wheel weights
- Engine coolant heater
- Steering accumulator
- Cab with heater and noise treatment
- Windshield with wiper
- 3 in. (76 mm) seat belt
- Automatic fire suppression system

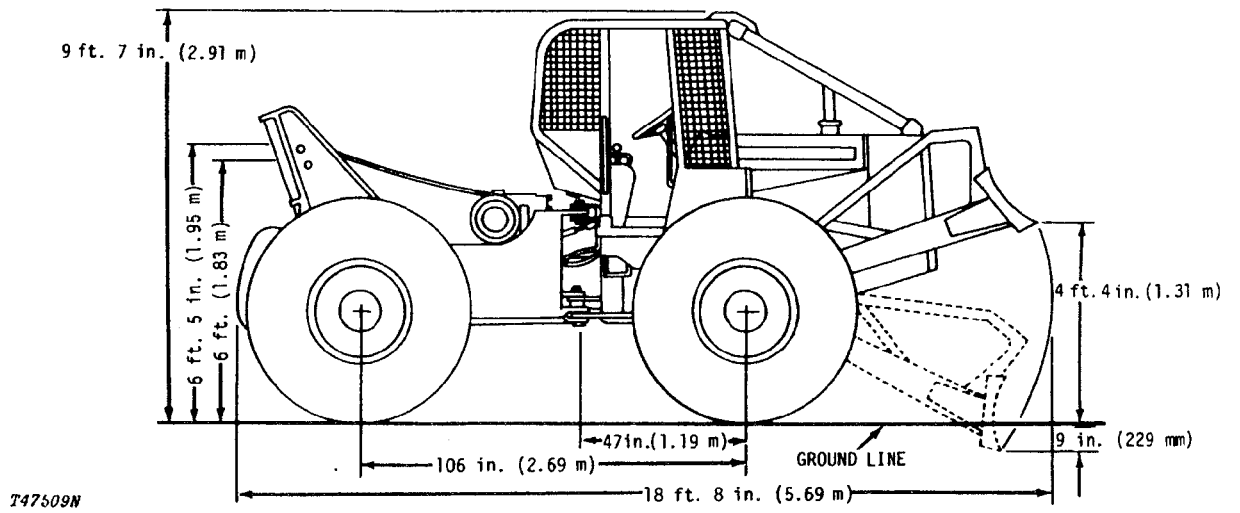

Side view dimensions are for skidder equipped with 23.1-26 tires and adjustable arch, and regular bumper in upper position.

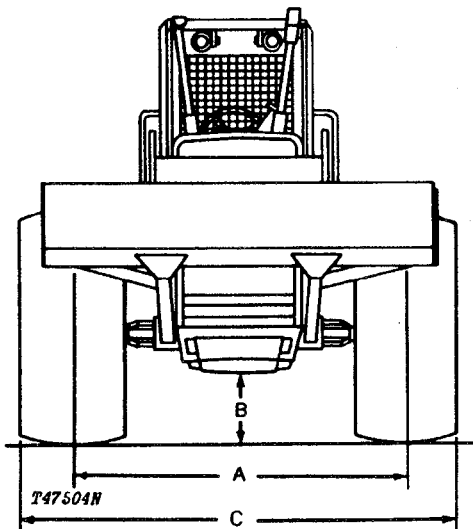

TIRE SIZE	A WHEEL TREAD	B GROUND CLEARANCE	C OVERALL WIDTH
18.4-26	76 in. (1.93 m)	1 ft. 8.5 in. (521 mm)	7 ft. 10.4 in. (2.40 m)
18.4-34	76.5 in. (1.94 m)	1 ft. 10 in. (559 mm)	7 ft. 11.4 in. (2.42 m)
23.1-26	80.8 in. (2.05 m)	1 ft. 9 in. (533 mm)	8 ft. 7.9 in. (2.64 m)
28.1-26	85.4 in. (2.17 m)	1 ft. 9.5 in. (546 mm)	9 ft. 5.5 in. (2.78 m)

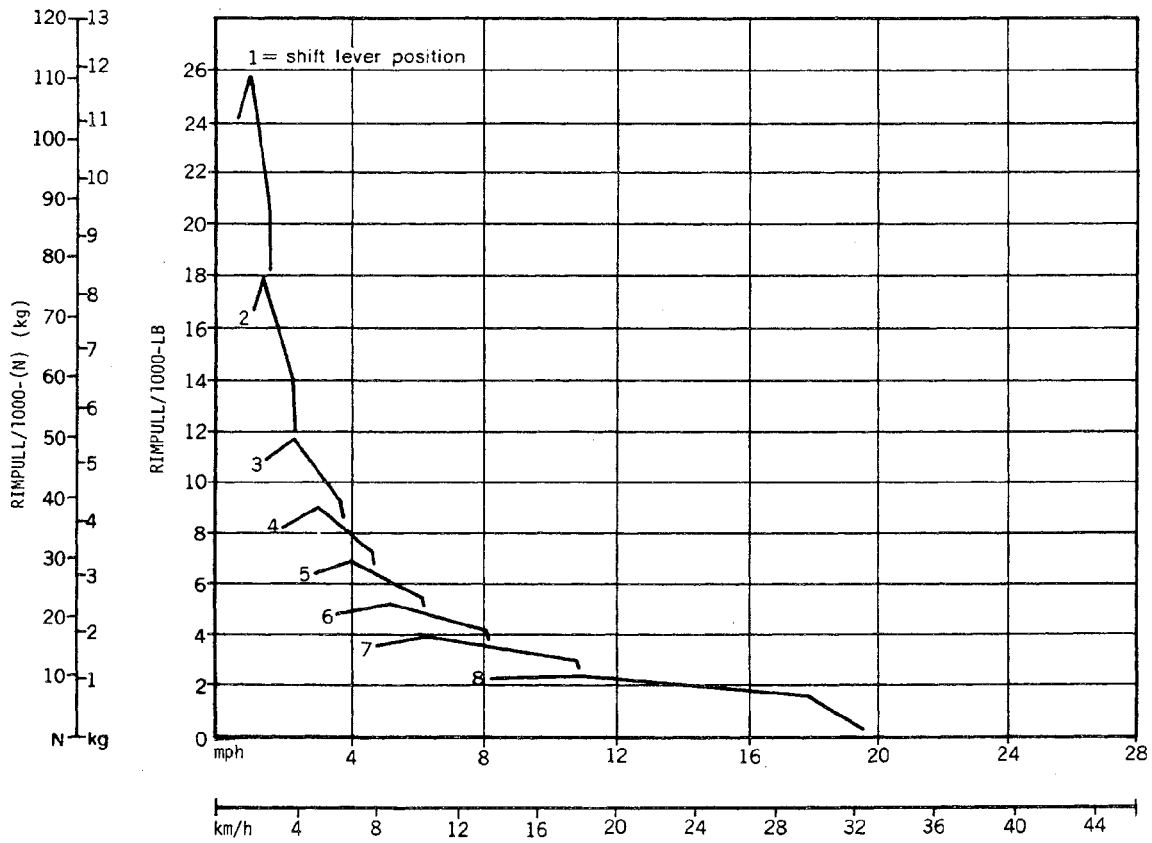

T47510N

GRAPPLE SKIDDER

(Specifications and design are subject to change without notice. Wherever applicable, specifications are in accordance with ICED and SAE Standards. Except where otherwise noted, these specifications are based on a unit equipped with 23.1-26, 10-ply-rating logging tires and standard equipment.)

Power @ (2200 engine rpm):	SAE	DIN
Gross	96 hp (71.5 kW*)	
Net	90 hp (67.1 kW)	91.3 PS

Net engine flywheel power is for an engine equipped with fan, air cleaner, water pump, lubricating oil pump, fuel pump, alternator and muffler. The gross engine power is without fan. Flywheel power ratings are under SAE standard conditions of 500-ft. altitude and 85°F temperature, and DIN 70 020 conditions (non-corrected). No derating is required up to 10,000 feet (3000 m) altitude.

*In the international system of units (SI) power is expressed in kilowatts (kW).

Engine:

John Deere turbocharged diesel 4-cylinder, 4-stroke cycle
 Bore and stroke 4.19x5 in. (106x127 mm)
 Piston displacement 276 cu. in. (4523 cm³)
 Compression ratio 16.7 to 1
 Maximum torque @ 1400 rpm ... 270 lb-ft (366 Nm)
 (37.32 kg-m)
 NACC or AMA (U.S. Tax) horsepower 28
 Lubrication Pressure system with full-flow filter
 Cooling Pressurized with thermostat and fixed
 bypass
 Fan Blower
 Air cleaner with restriction indicator Dry
 Electrical system 12-volt with alternator
 Batteries (2) Reserve capacity: 170 minutes

Differentials:

Front and rear .. Full differentials with hydraulic lock

Engine Clutch Disconnect:

Hand-operated, spring-loaded, dry-disk. Single plate, 12 in. (305 mm).

Transmission:

Power Shift with planetary gears, hydraulically actuated wet-disk clutches and brakes; provides 8 speeds forward—4 reverse. Controlled by single lever on console.

Travel Speeds (2200 engine rpm, no tire slip):

Forward: 1.7 mph (2.7 km/h) to 17.9 mph (28.5 km/h)
 Reverse: 2.0 mph (3.2 km/h) to 5.8 mph (9.3 km/h)

Drive Axles:

Four-wheel drive with inboard planetary gears on all axles. Front axle oscillates 15 degrees above and below horizontal. 20 in. (508 mm) total travel at tire center line.

Brakes:

Hydraulic power actuated, dual controlled disks on 4 wheels, lockable for winching. Hand-operated mechanical brake for parking and emergency stop.

Power Steering:

Articulated frame hydraulically actuated by dual cylinders.
 Turning radius 16 ft. 4 in. (4.97 m)
 Turning clearance 34 ft. 5 in. (10.49 m)

Hydraulic System:

Closed-center constant pressure. Variable-displacement pump driven from crankshaft... 33.5 gpm (126.5 L/min) 2000 psi (137.9 bar) (140.6 kg/cm²) @ 2200 engine rpm. Full flow filtration. Oil cooler integral with radiator.

Hydraulic Cylinders:	Bore	Stroke
Lift (2)	4.0 in. (102 mm)	30 in. (762 mm)
Grapple (1)	5.25 in. (133 mm)	17 in. (432 mm)
Cylinder rods	Ground, heat-treated, chrome-plated, polished	
Lift cylinder rods	2-in. (51 mm) dia.	
Grapple cylinder rod	2.25 in. (57 mm) dia.	

Tires:

- 23.1-26, 16-ply-rating, kevlar-ply, LS2*
- 18.4-34, 10-ply-rating, steel-ply, LS2
- 23.1-26, 10-ply-rating, steel-ply, LS2
- 28.1-26, 10-ply-rating, steel-ply, LS3
- 28.1-26, 14-ply-rating, steel-ply, LS2

*Canada only

Capacities:

	U.S.	Liters
Fuel tank	42 gal.	159.0
Cooling system	8 gal.	30.3
Engine lubrication, including filter ...	15 qt.	14.2
Transmission and hydraulic system ..	9 gal.	34.1
Front differential	4.5 gal.	17.0
Rear differential	4.5 gal.	17.0
Winch	2.5 gal.	9.5

SAE Operating Weight 18,675 lb. (8 471 kg)

Winch:

Cable capacities*:

- 1/2-in. (12.7 mm) cable 217 ft. (66.1 m)
- 5/8-in. (15.8 mm) cable 142 ft. (43.3 m)
- 3/4-in. (19.1 mm) cable 100 ft. (30.5 m)

*Calculated: No allowance made for loose or uneven spooling.

Line pull (maximum engine torque):

- Bare drum 30,541 lb. (136.89 kN) (13 853 kg)
- Full drum 18,794 lb. (84.24 kN) (8 525 kg)

Line speed (2200 rpm):

- Bare drum 115 fpm (35.1 m/min)
- Full drum 187 fpm (56.9 m/min)

Hydraulic control

- 6 ft. 11 in. (2.11 m)
- s) 1 ft. 8 in. (508 mm)
- ler) 2 ft. 3 in. (686 mm)
- ive ground level 4 ft. 4 in. (1.31 m)
- elow ground level 9 in. (229 mm)

Additional Standard Equipment:

- Muffler
- Fuel gauge
- Engine oil pressure gauge
- Alternator warning light
- Water temperature gauge
- Transmission oil temperature gauge
- Transmission oil pressure warning light
- Parking brake warning light and buzzer
- Transistorized voltage regulator
- Electric hour meter
- Key switch with pushbutton safety start
- Horn
- Fire extinguisher
- Flanged axles
- John Deere winch
- Cold weather starting aid
- Heavy duty starter
- Hinge lock bar
- Engine side shields
- Deluxe seat with suspension
- Cigar lighter
- Foot throttle
- Hand throttle
- Lights
- Front blade
- Roll-over protective structure (ROPS) with canopy, seat belt, brush screens, and limb risers
- Vandal protection
- Reinforced bottom guard

Special Equipment:

- Wheel weights
- Engine coolant heater
- Steering accumulator
- Cab with heater and noise treatment
- Windshield with wiper
- 3 in. (76 mm) seat belt
- Fairlead for winch
- Automatic fire suppression system

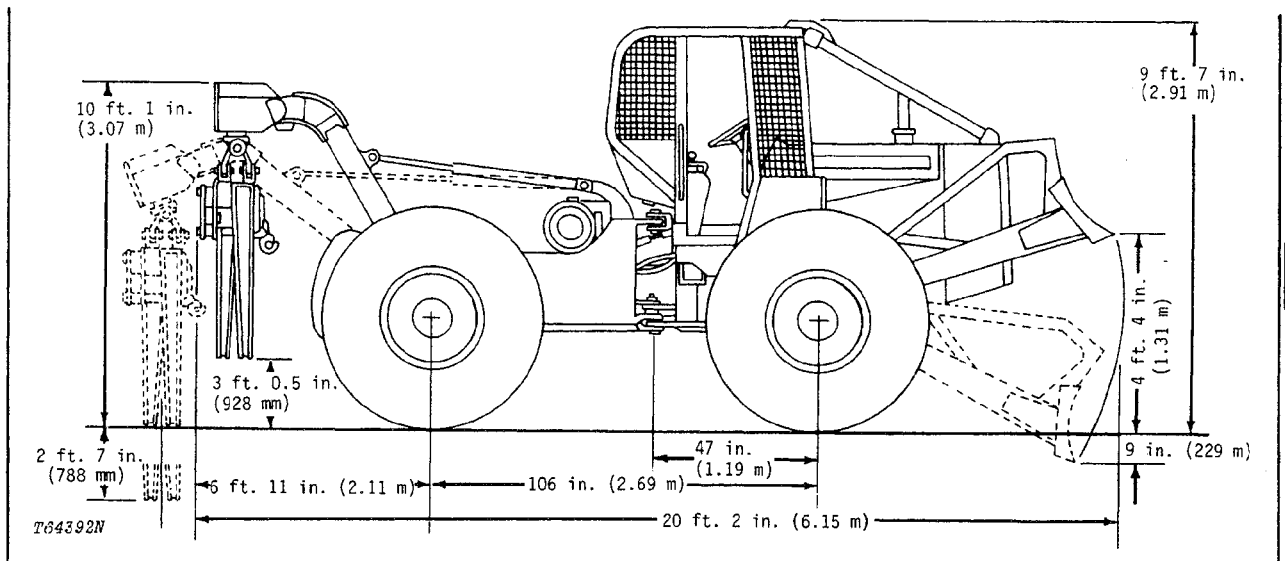

Side view dimensions are for skidder equipped with 23.1-26 tires, grapple open.

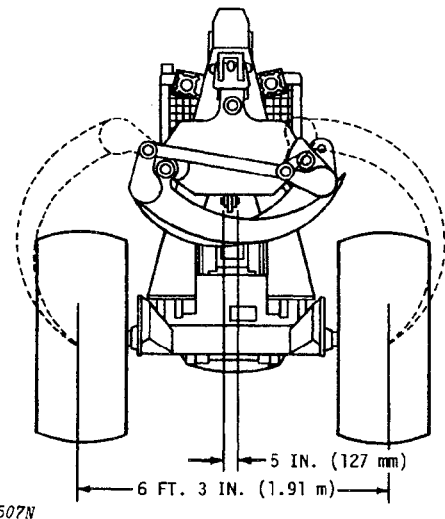
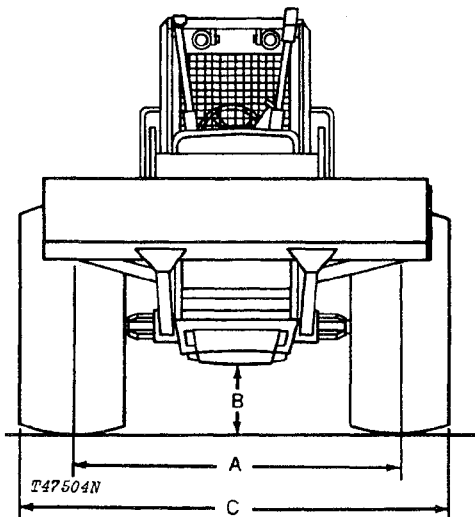

TIRE SIZE	A WHEEL TREAD	B GROUND CLEARANCE	C OVERALL WIDTH
18.4-34	76.5 in. (1.94 m)	1 ft. 10 in. (559 mm)	7 ft. 11.4 in. (2.42 m)
23.1-26	80.8 in. (2.05 m)	1 ft. 9 in. (533 mm)	8 ft. 7.9 in. (2.69 m)
28.1-26	85.4 in. (2.17 m)	1 ft. 9.5 in. (546 mm)	9 ft. 5.5 in. (2.78 m)

DIMENSIONS NOT SHOWN:

Tip closure force 6300 lb. (28.24 kN) (2 858 kg)
 Enclosure area, tips meeting 8 sq. ft. (0.74 m²)